

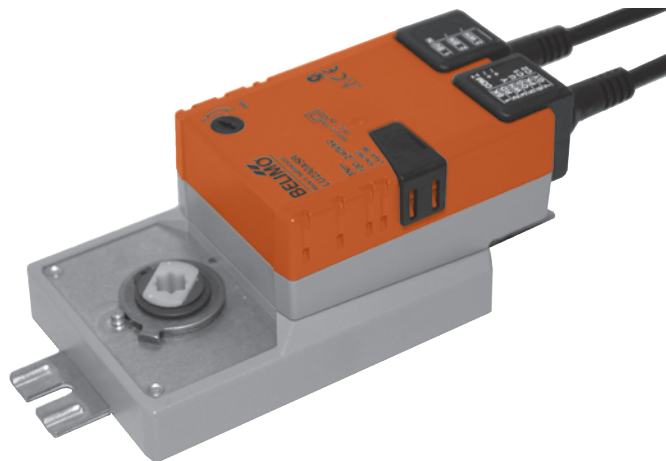

Full-rotation actuator for operating air control dampers and shutters in ventilation and air-conditioning systems for building services installations

- For air control dampers up to approx. 0.6 m²
- Torque 3 Nm
- Nominal voltage AC 100 ... 240 V
- Control: modulating DC 0 ... 10 V, position feedback DC 2 ... 10 V
- Spindle driver: Form-fit 12 mm or 8 mm (with insert)

Technical data

Electrical data	Nominal voltage	AC 100 ... 240 V, 50/60 Hz	
	Nominal voltage range	AC 85 ... 265 V	
	Power consumption	In operation	2 W @ nominal torque
		At rest	1 W
	For wire sizing	4.5 VA	
Connection	Power supply	Cable 1 m, 2 x 0.75 mm ²	
	Signals	Cable 1 m, 4 x 0.75 mm ²	
Functional data	Torque	Min. 3 Nm @ nominal voltage	
	Control	Control signal Y	DC 0 ... 10 V, Eingangswiderstand typisch 100 kΩ
		Working range	DC 2 ... 10 V = 0 ... 330° ↺
	Position feedback (Measuring voltage)	DC 2 ... 10 V, max. 1 mA	
	Auxiliary supply	DC 24 V ±30%, max. 10 mA	
	Position accuracy	±5%	
	Direction of rotation	Reversible with switch	
	Direction of rotation at Y = 0 V	at switch position ↺ resp. ↻	
	Manual override	Gearing latch disengaged with pushbutton, self-resetting	
	Angle of rotation	0 ... 330° ↺, permanently set	
	Running time	150 s / 360° ↺	
	Sound power level	max. 35 dB (A)	
	Spindle driver	Form-fit 12 mm or 8 mm (with insert)	
Safety	Protection class	II Totally insulated 	
	Degree of protection	IP54 in any mounting position	
	EMC	CE according to 89/336/EEC	
	Low voltage directive	CE according to 73/23/EEC	
	Mode of operation	Type 1 (EN 60730-1)	
	Rated impulse voltage	Voltage	4 kV (EN 60730-1)
		Control	0.8 kV (EN 60730-1)
	Control Pollution Degree	3 (EN 60730-1)	
	Ambient temperature range	-30 ... +50 °C	
	Non-operating temperature	-40 ... +80 °C	
Ambient humidity range	95% r.H., non-condensating (EN 60730-1)		
Maintenance	Maintenance-free		
Dimensions / Weight	Dimensions	See «Dimensions» on page 2	
	Weight	Approx. 650 g	

Safety notes

- The actuator is not allowed to be used outside the specified field of application, especially not in aircraft or any other form of air transport.
- **Caution: Power supply voltage !**
- **Assembly must be carried out by trained personnel. Any legal regulations or regulations issued by authorities must be observed during assembly.**
- The device may only be opened at the manufacturer's site. It does not contain any parts that can be replaced or repaired by the user.

Safety notes

Continued

- The retaining ring for angle of rotation limiting must not be removed.
- Mechanical interfaces which are not expressly envisaged by BELIMO for the LU230ASR must not be created.
- The cable must not be removed from the device.
- When calculating the required torque, the specifications supplied by the damper manufacturers (cross section, design, installation site), and the air flow conditions must be observed.
- The device contains electrical and electronic components and is not allowed to be disposed of as household refuse. All locally valid regulations and requirements must be observed.

Product features

Mode of operation	The actuator is controlled by means of a standard control signal DC 0 ... 10 V. It opens to the position dictated by this signal. The measuring voltage U allows the damper position (0 ... 100%) to be electrically indicated and serves as a follow-up control signal for other actuators.
Simple direct mounting	Form-fit direct mounting on a 12 mm or 8 mm damper spindle (with insert). The actuator can also be optionally equipped with a 10 mm form fit or an 8 ... 12 mm clamp (see «Accessories»).
Manual override	Manual operation is possible with the self-resetting pushbutton (the gearing latch remains disengaged as long as the pushbutton is pressed).
High functional reliability	The actuator is overload-proof, requires no limit switches and automatically stops when the end stop is reached.

Accessories

	Description	Data sheet
Electrical accessories	Positioner, type SGA24, SGF24 and SGE24	T2 - SG..24
Mechanical accessories	Form-fit insert 10 x 10 mm, type ZF10-LU Clamp with 8 ... 12 mm clamping range and anti-rotation strap, type K-LU	

Electrical installation

Wiring diagram

Notes

- Caution: Power supply voltage !
- Other actuators can be connected in parallel. Please note the performance data.

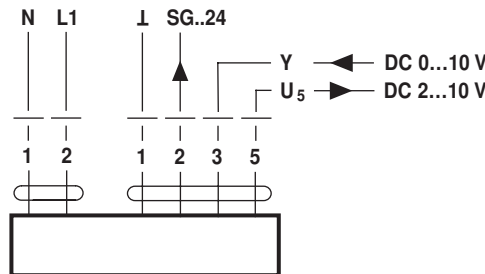

Dimensions [mm]

Dimensional drawings

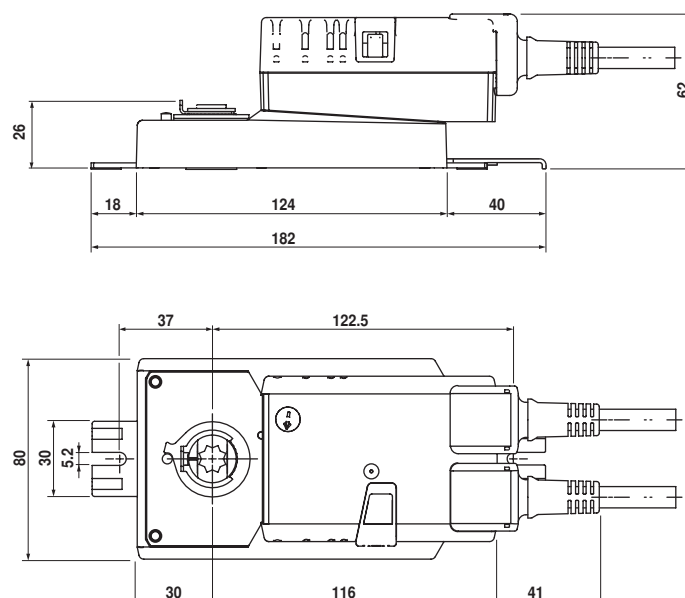

Damper spindle	Length	■ I
	min. 20	12 or 8 (with insert)

