

Damper actuator for operating air control dampers in ventilation and air-conditioning systems for building services installations

- For air control dampers up to approx. 0.4 m²
- Torque 2 Nm
- Nominal voltage AC/DC 24 V
- Control: Open-close or 3-point
- Integrated auxiliary switch
- Running time 35 s

Technical data

Electrical data	Nominal voltage	AC 24 V, 50/60 Hz DC 24 V	
	Nominal voltage range	AC/DC 19.2 ... 28.8 V	
	Power consumption	In operation	1.5 W @ nominal torque
		At rest	0.2 W
		For wire sizing	2.5 VA
	Auxiliary switch	1 x SPDT, 1 mA ... 3 (0.5) A, AC 250 V <input type="checkbox"/> (0 ... 100% adjustable)	
Connection	Motor	Cable 1 m, 3 x 0.75 mm ²	
	Auxiliary switch	Cable 1 m, 3 x 0.75 mm ²	
Functional data	Torque (nominal torque)	Min. 2 Nm @ nominal voltage	
	Direction of rotation	Reversible with switch 0 ↺ or 1 ↻	
	Manual override	Gearing latch disengaged with pushbutton, self-resetting	
	Angle of rotation	Max. 95° ↔, limited on both sides by means of adjustable, mechanical end stops	
	Running time	35 s	
	Sound power level	Max. 35 dB (A)	
	Position indication	Mechanical, pluggable	
Safety	Protection class	III Safety extra-low voltage	
	Degree of protection	IP54 in any mounting position	
	EMC	CE according to 89/336/EEC	
	Mode of operation	Type 1 (to EN 60730-1)	
	Rated impulse voltage	0.8 kV (to EN 60730-1)	
	Control pollution degree	3 (to EN 60730-1)	
	Ambient temperature range	-30 ... +50 °C	
	Non-operating temperature	-40 ... +80 °C	
	Ambient humidity range	95% r.H., non-condensating (EN 60730-1)	
	Maintenance	Maintenance-free	
Dimensions / Weight	Dimensions	See «Dimensions» on page 2	
	Weight	Approx. 500 g	

Safety notes

- The damper actuator is not allowed to be used outside the specified field of application, especially in aircraft or any other form of air transport.
- Assembly must be carried out by trained personnel. Any legal regulations or regulations issued by authorities must be observed during assembly.
- The device may only be opened at the manufacturer's site. It does not contain any parts that can be replaced or repaired by the user.
- The cable must not be removed from the device.
- When calculating the required torque, the specifications supplied by the damper manufacturers (cross section, design, installation site), and the air flow conditions must be observed.
- The device contains electrical and electronic components and is not allowed to be disposed of as household refuse. All locally valid regulations and requirements must be observed.

Product features

- Simple direct mounting** Simple direct mounting on the damper spindle with a universal spindle clamp, supplied with an anti-rotation strap to prevent the actuator from rotating.
- Manual override** Manual operation is possible with the self-resetting pushbutton (the gearing latch remains disengaged as long as the pushbutton is pressed).
- Adjustable angle of rotation** Adjustable angle of rotation with mechanical end stops.
- High functional reliability** The actuator is overload-proof, requires no limit switches and automatically stops when the end stop is reached.
- Flexible signalization** Flexible signalization with adjustable auxiliary switch (0 ... 100%).

Accessories

	Description	Data sheet
Electrical accessories	Auxiliary switch S..A..	T2 - S..A..
	Feedback potentiometer P..A..	T2 - P..A..
Mechanical accessories	Shaft extension AV6-20	T2 - Z-LM..A..

Electrical installation

Wiring diagrams

- Notes**
- Connection via safety isolating transformer.
 - Other actuators can be connected in parallel. Please note the performance data.

Open-close control

3-point control

Direction of rotation



Auxiliary switch

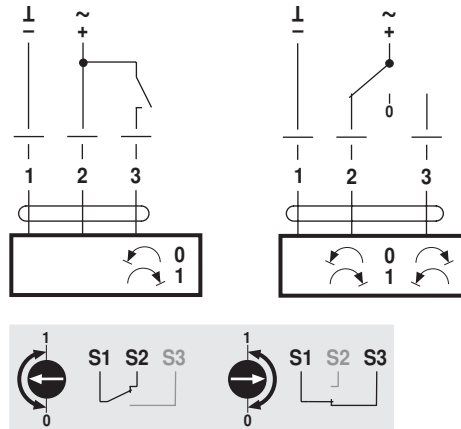

Dimensions [mm]

Dimensional drawings

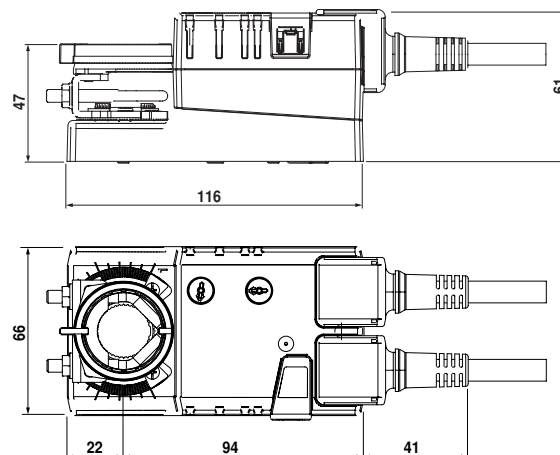

Damper spindle	Length	
	min. 37	6 ... 20

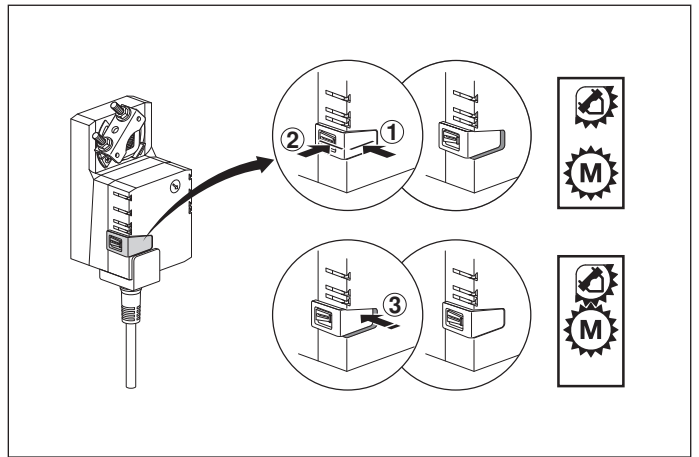
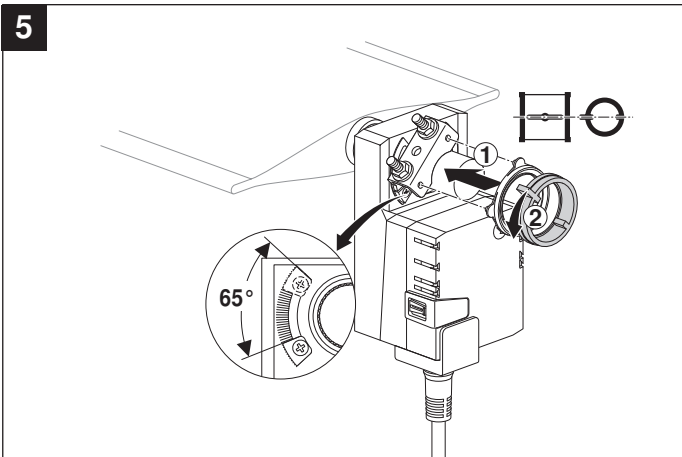
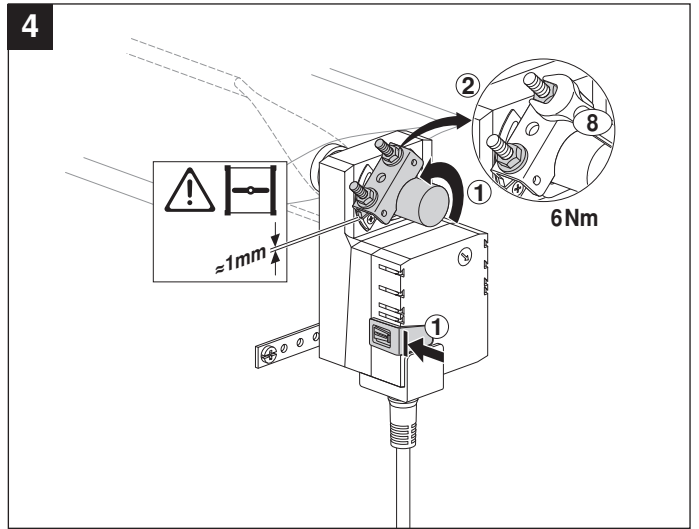
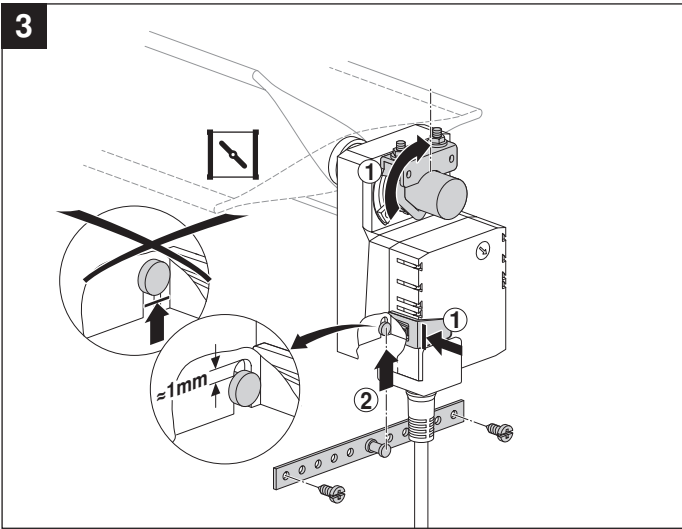
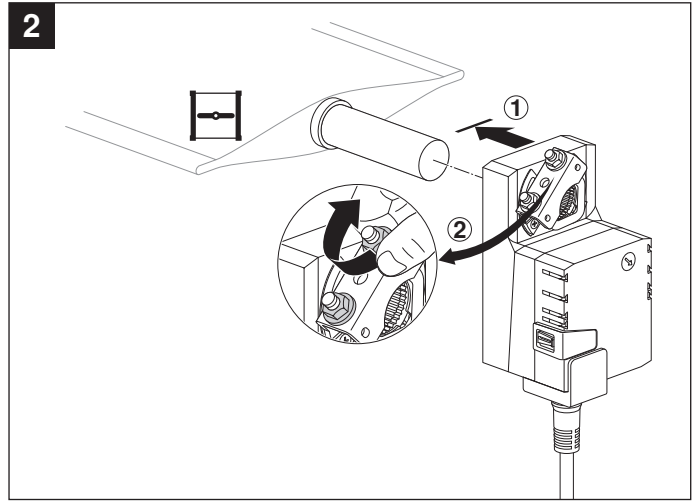
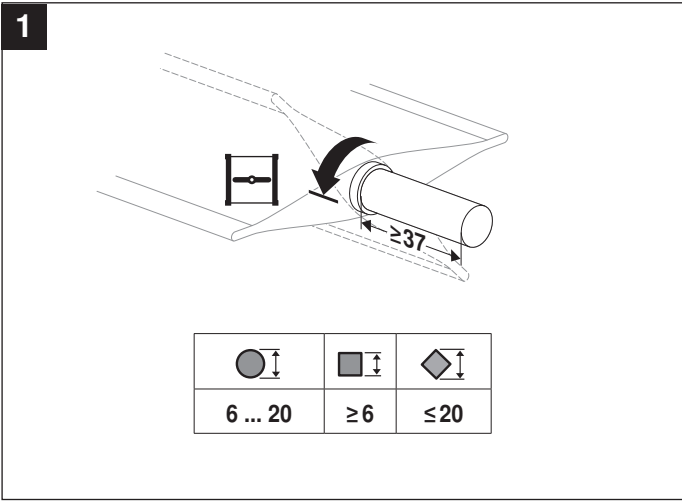



AC 24 V / DC 24 V

DC 48 ... 110 V
(LM72A..)

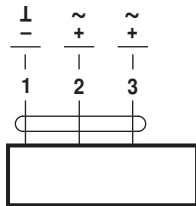

LM24A.. LMC24A..
LM72A.. TMC24A..

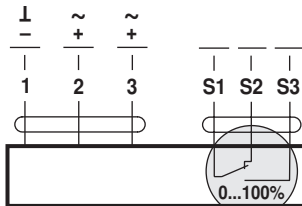

LM24A-S.. TMC24A-S..
LM72A-S..

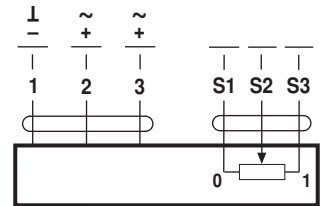

LM24AP5..

AC 100 ... 240 V

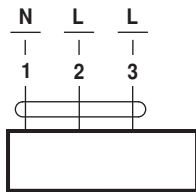

LM230A.. LMC230A..
TMC230A..

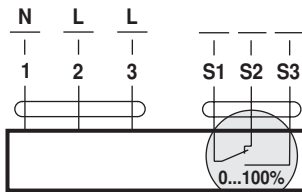

LM230A-S.. TMC230A-S..

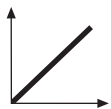
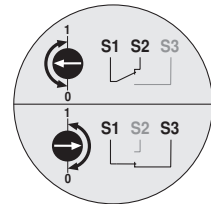

AC 24 V / DC 24 V

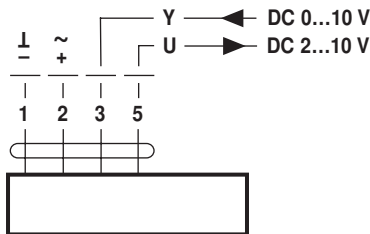

LM24A-SR.. LMC24A-SR..
LM24A-MF.. TMC24A-SR..

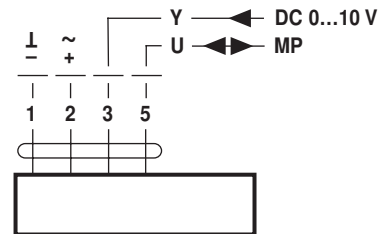

LM24A-MP..

DC 48 ... 110 V
(LM72A-SR..)

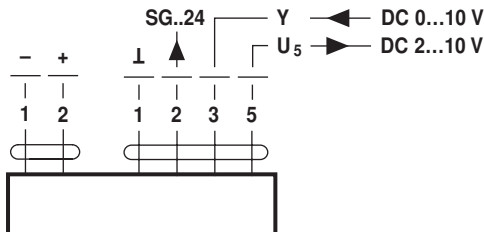

LM72A-SR..

AC 100 ... 240 V

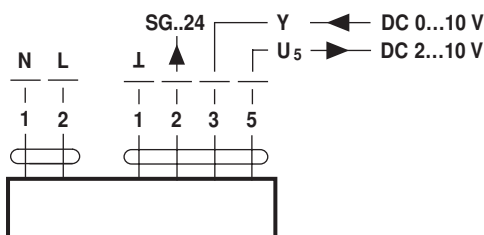

LM230ASR.. TMC230ASR..

AC 24 V / DC 24 V
(LM24A-V / VR..)

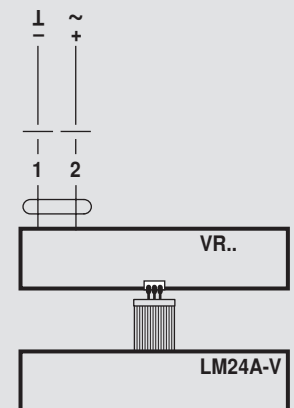

LM24A-V / VR..