

Spring-return actuator for adjusting dampers with safety functions (e.g. frost and smoke control, hygiene, etc.) in technical building installation

- Damper size up to approx. 0.5 m²
- Nominal torque 2.5 Nm
- Nominal voltage AC/DC 24 V
- Control open-close

Technical data

Electrical data	Nominal voltage	AC/DC 24 V
	Nominal voltage frequency	50/60 Hz
	Nominal voltage range	AC 19.2 V ... 28.8 V / DC 21.6 V ... 28.8 V
	Power consumption in operation	2.5 W
	Power consumption in rest position	1.5 W
	Power consumption for wire sizing	5 VA
	Connection supply / control	Cable 1 m, 2 x 0.75 mm ²
Functional data	Torque motor	Min. 2.5 Nm
	Torque spring-return	Min. 2.5 Nm
	Direction of rotation motor	Can be selected by mounting L / R
	Direction of rotation spring-return	Can be selected by mounting L / R
	Angle of rotation	Max. 95° adjustable 37 ... 100% with integrated mechanical limitation
	Running time motor	75 s / 90°
	Running time emergency control function	<25 s / 90°
	Sound power level motor max.	50 dB (A)
	Spindle driver	Universal spindle clamp 6...12 mm
	Position indication	Mechanical
	Service life	Min. 60,000 security settings
Safety	Protection class IEC/EN	III Safety extra-low voltage
	Degree of protection IEC/EN	IP42
	EMC	CE according to 2004/108/EC
	Certification IEC/EN	Certified to: IEC/EN 60730-1 and IEC/EN 60730-2-14
	Principle of operation	Type 1.AA
	Overvoltage category	III
	Control pollution degree	3
	Ambient temperature	-30°C ... 50°C
	Non-operating temperature	-40°C ... 80°C
	Ambient humidity	95% r.h., non-condensing
Maintenance	Maintenance-free	
Weight	Weight approx.	0.6 kg

Safety notes

- The spring-return actuator is not allowed to be used outside the specified field of application, especially in aircraft or in any other airborne means of transport.
- Only authorised specialists may carry out installation. All applicable legal or institutional installation regulations must be complied with during installation.
- The device may only be opened at the manufacturer's site. It does not contain any parts that can be replaced or repaired by the user.
- The cable must not be removed from the device.
- The device contains electrical and electronic components and is not allowed to be disposed of as household refuse. All locally valid regulations and requirements must be observed.

Product features

- Principle of operation** The actuator moves the damper to the operating position at the same time as tensioning the return spring. The damper is turned back to the safety position by spring energy when the supply voltage is interrupted.
- Direct mounting** Simple direct mounting on the damper spindle with a universal spindle clamp, supplied with a universal mounting bracket to prevent the actuator from rotating.
- High functional reliability** The actuator is overload protected and automatically stops when the end stop is reached.

Electrical installation

**Notes**

- Connection via safety isolating transformer.
- Parallel connection of other actuators possible. Observe the performance data.

Wiring diagrams

AC/DC 24 V, open-close

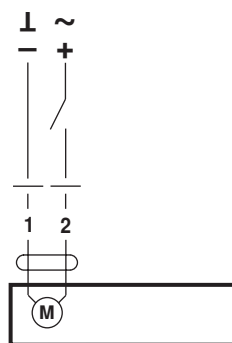

Cable colours:
1 = red
2 = black

Dimensions [mm]

Dimensional drawings

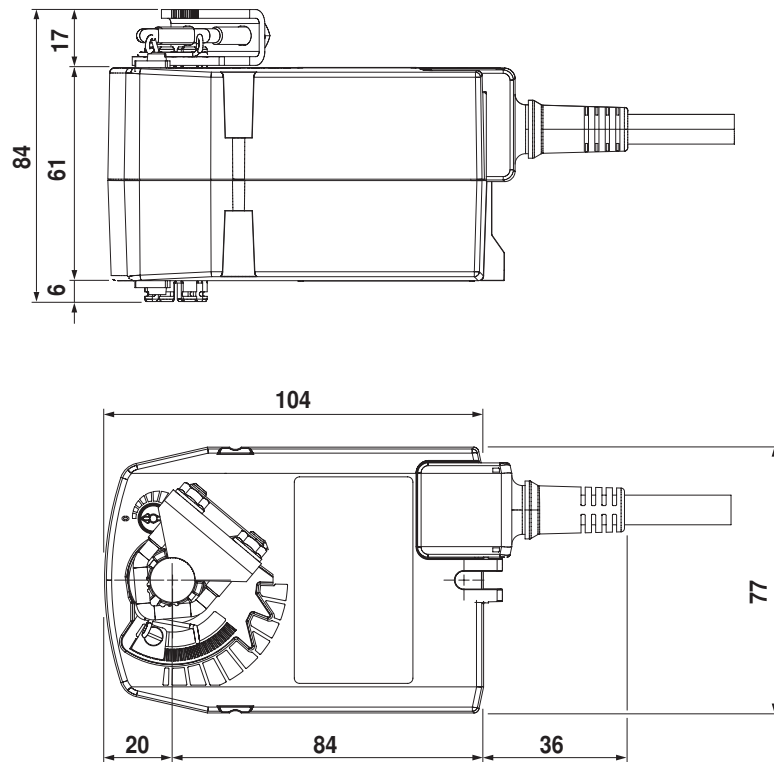

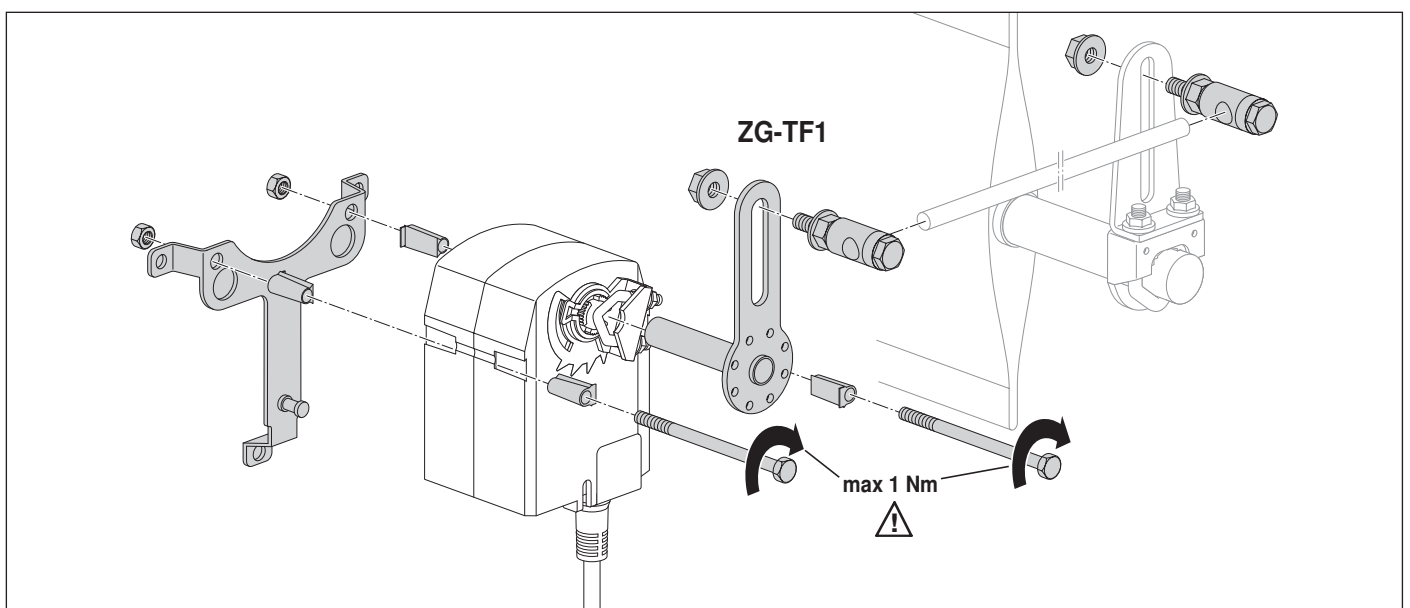
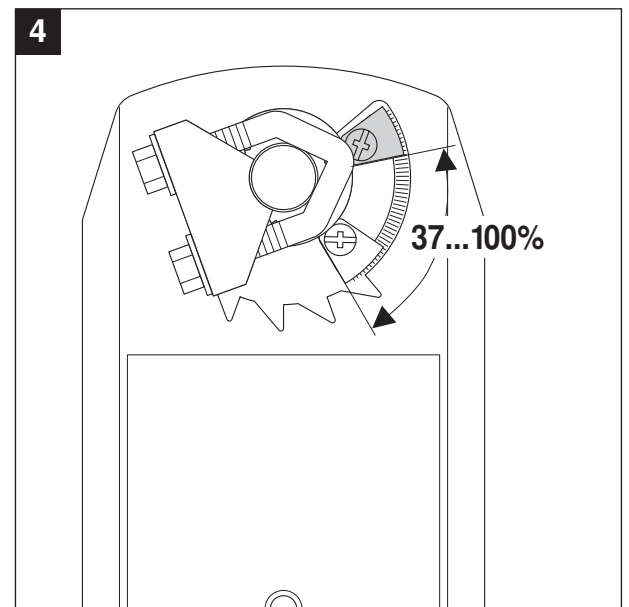
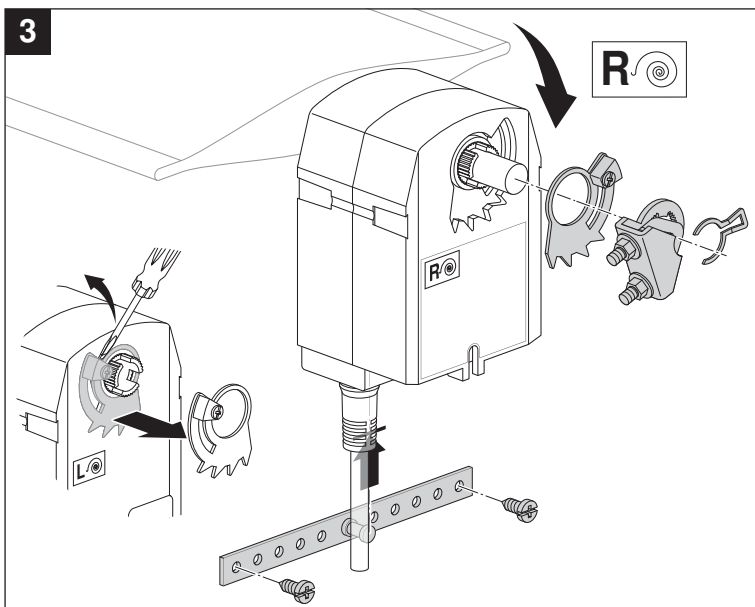
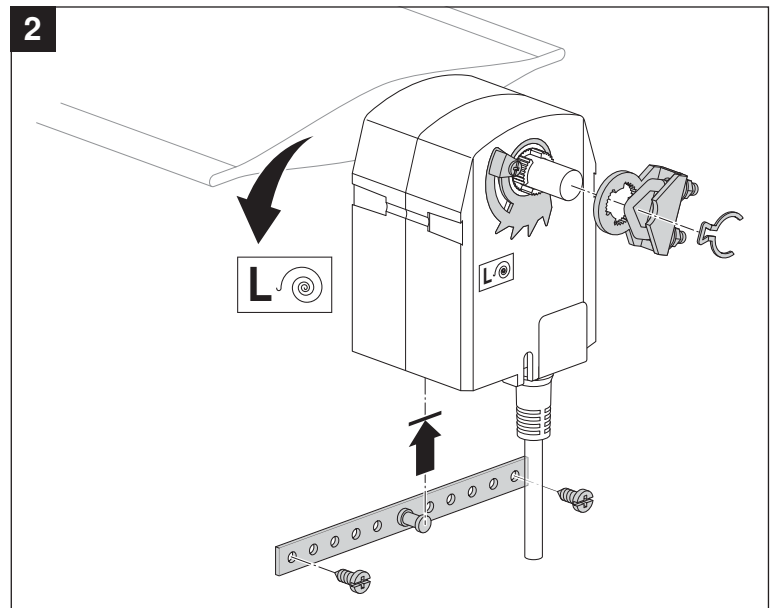
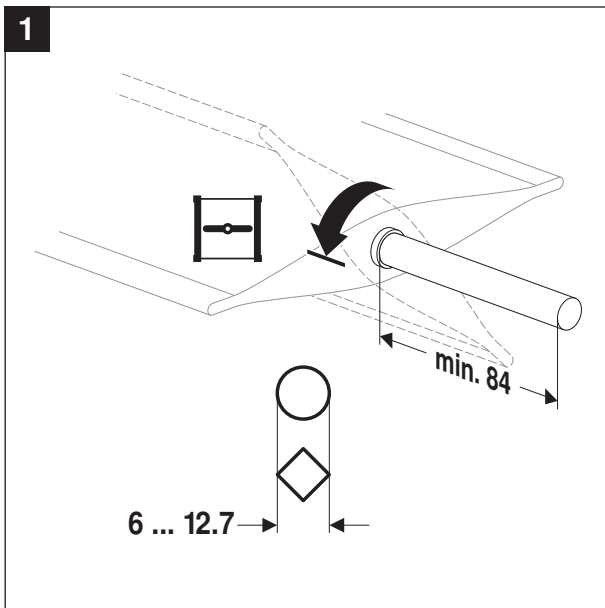

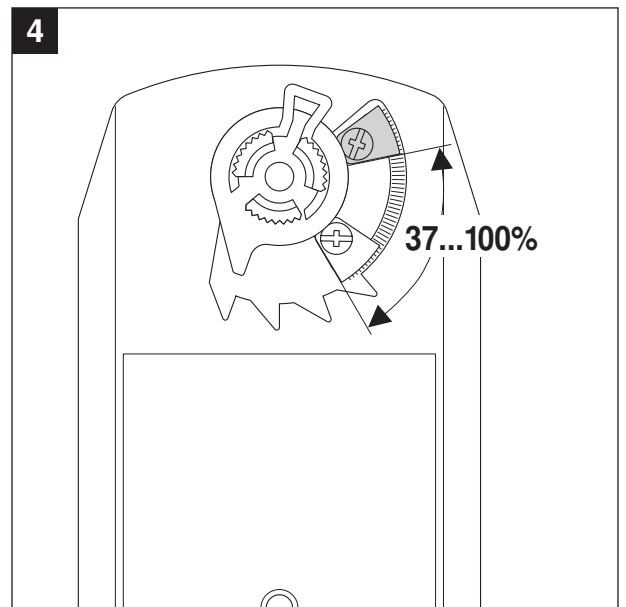
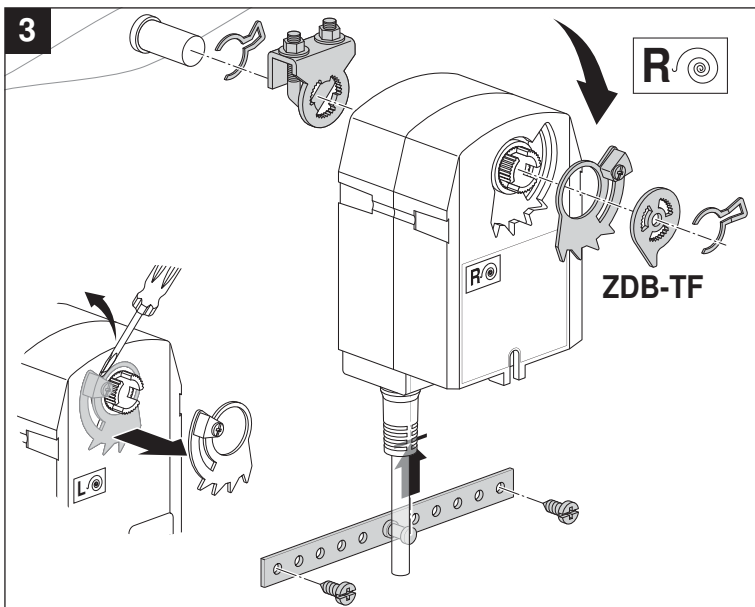
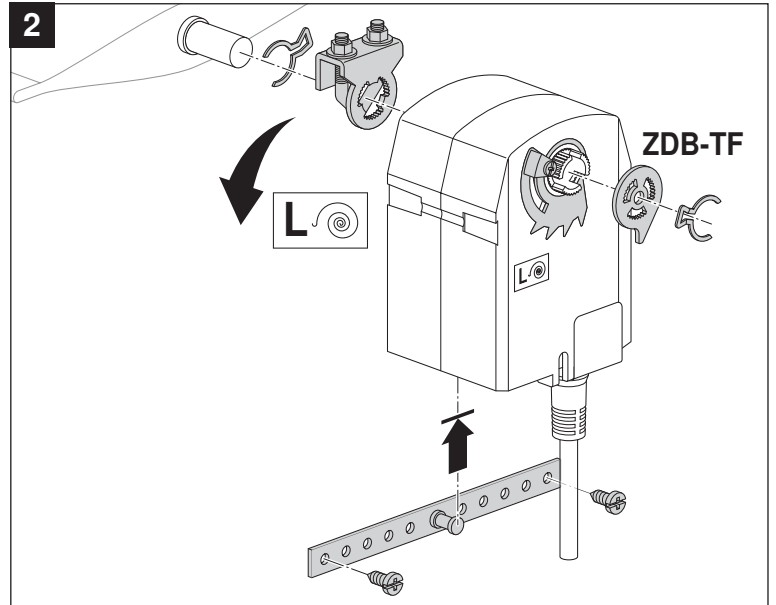
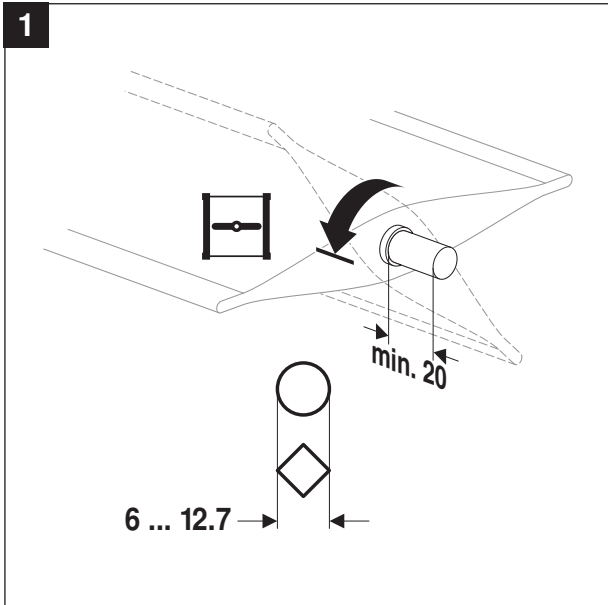

AC 230 V
AC 24 V / DC 24 V

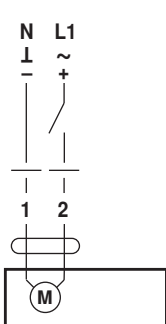

TF230 / TF24

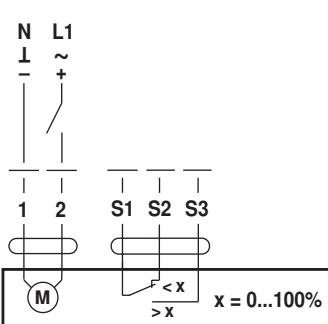

TF230-S / TF24-S

AC 24 V

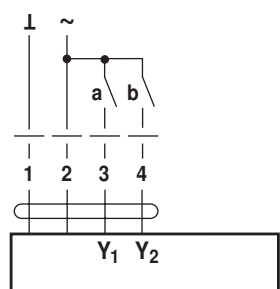

TF24-3



AC 24 V / DC 24 V

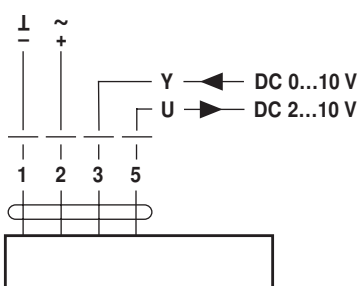

TF24-SR

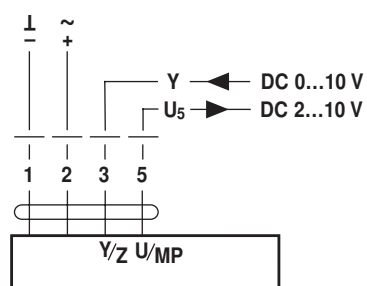

TF24-MFT